

FS-AELDER Insert compatible with Aelderman®, including the Mini Expansion



Assembly Instructions

The package contains five sheets: 1 double sheet and 3 single sheets.

After assembly the trays are put in up to two layers in the original game box.

Ordinary PVA glue is required when assembling each tray.

Please make sure you dry-assemble each tray correctly before gluing it together.

Please check www.foldedspace.com for general assembly tips.

FS-AELDER

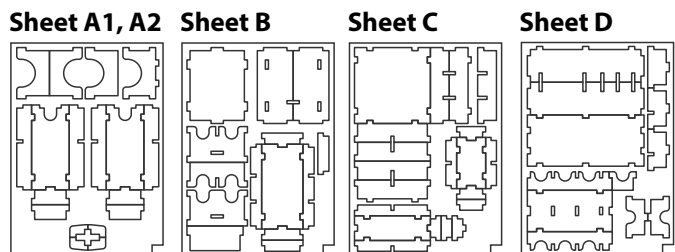
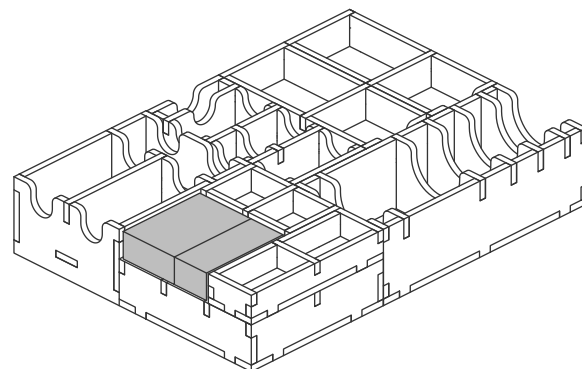

Tray 1

Sheet C

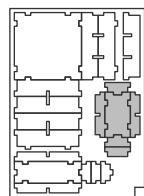

Step 1

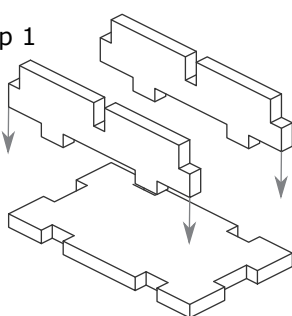

Step 2

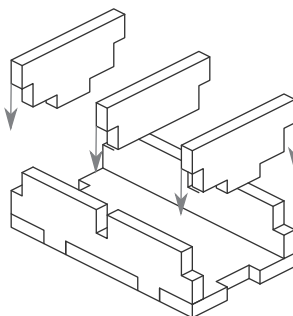

Finished tray

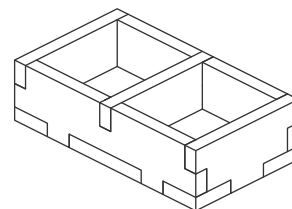

Tray 2

Sheet B

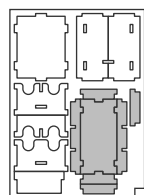

Step 1

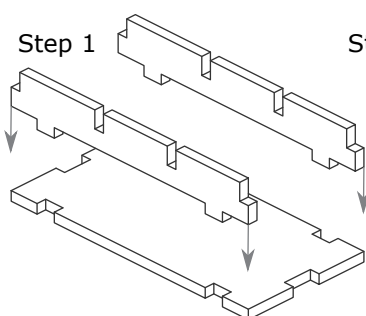

Step 2

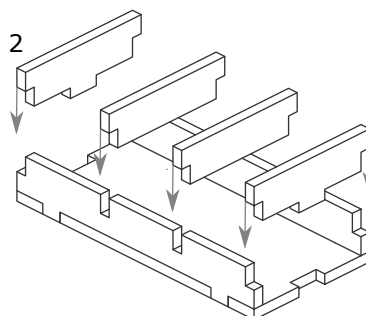

Finished tray

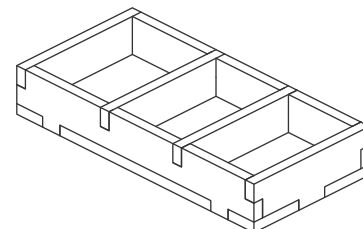

Tray 3

Sheet C

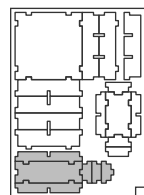

Step 1

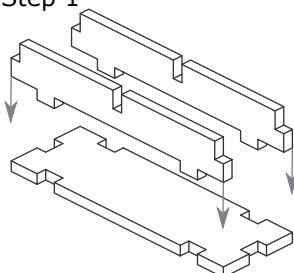

Step 2

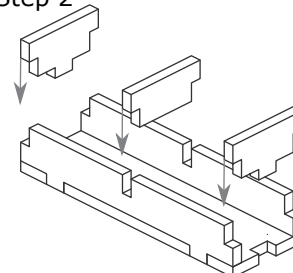

Finished tray

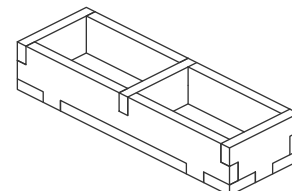

Tray 4a, 4b, 4c, 4d (the trays are identical)

Sheet A1, A2

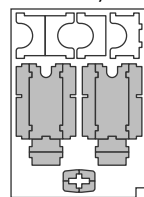

Step 1

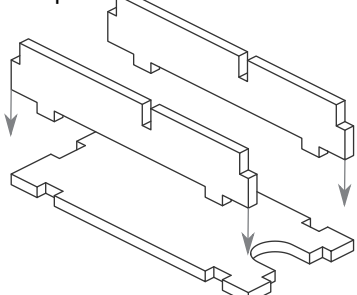

Step 2

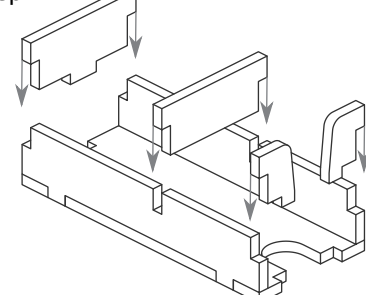

Finished tray

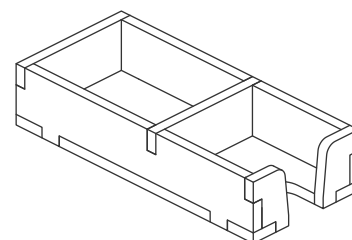

FS-AELDER Insert compatible with Aelderman®, including the Mini Expansion



Tray 5

Sheet C

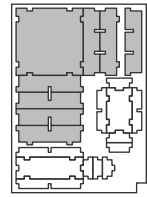

Step 1

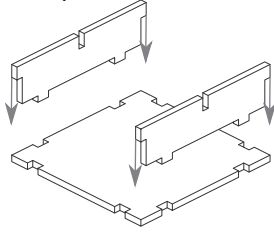

Step 2

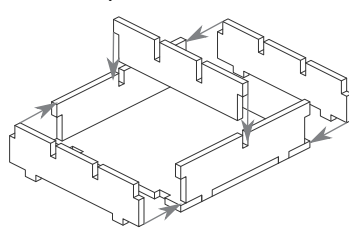

Step 3

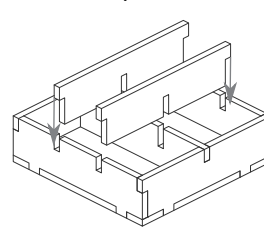

Finished tray

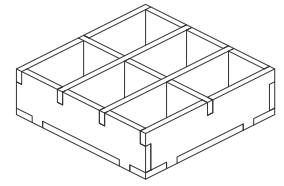

Tray 6

Sheet A1, A2 Sheet D

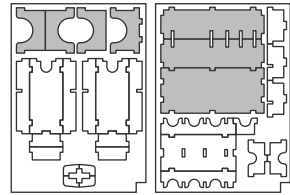

Step 1

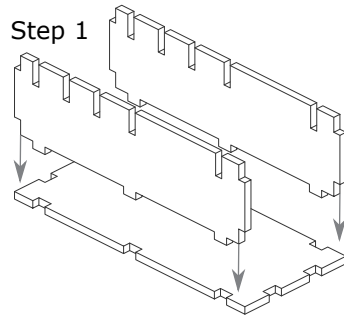

Step 2

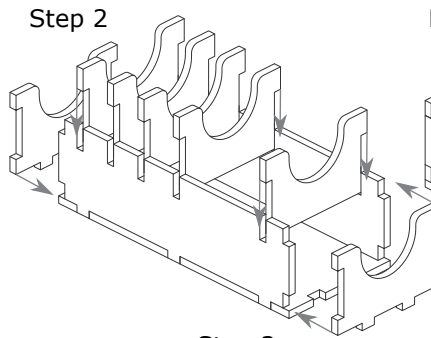

Finished tray

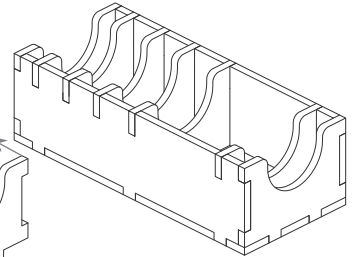

Tray 7

Sheet B

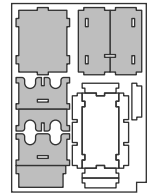

Step 1

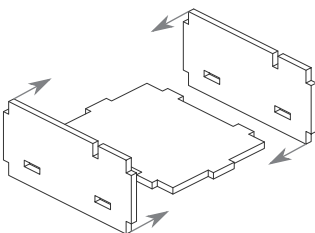

Step 2

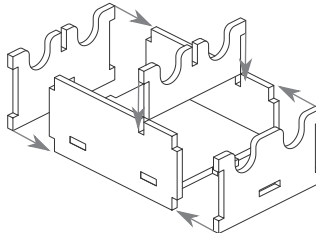

Step 3

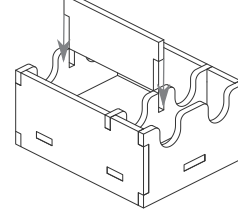

Finished tray

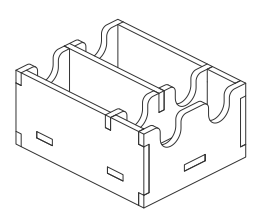

Tray 8

Sheet D

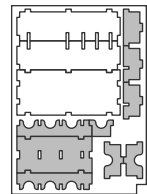

Step 1

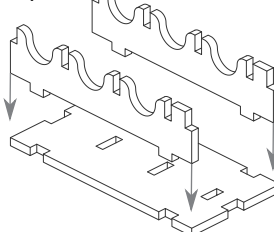

Step 2

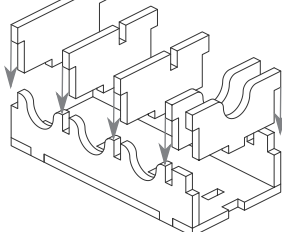

Step 3

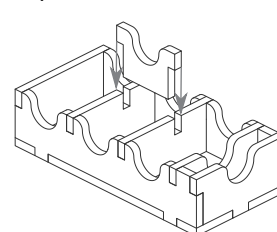

Finished tray

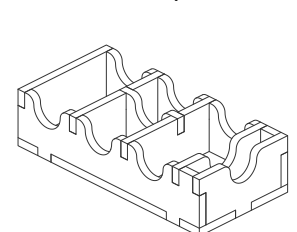

FS-AELDER

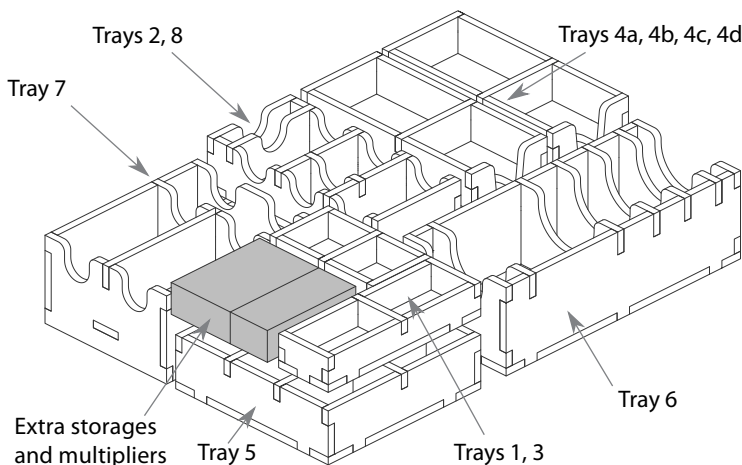

Please check www.foldedspace.com for photos of this insert in use.

Tray legend

- Tray 1 - beer and pelt resource markers
- Tray 2 - coins (metal or card) and action points
- Tray 3 - fish and wheat resource markers
- Tray 4a, b, c, d - player pieces, including barriers and income markers
- Tray 5 - remaining resource markers
- Tray 6 - game cards and round indicators
- Tray 7 - building tiles and action cards
- Tray 8 - improvements, start boosters and period indicators

Note: the game includes a lot of boards and other large tiles. Please check our website for images of how these are placed together on top of the insert trays.